

PR1/T19 Combination Transmission

and extends driveline service life. Multi-disc clutch packs are designed to keep the transmission running cool during frequent shifting and inching.

A heavy-duty version of the PR2 has additional clutch plates to handle tough applications. Optional ratios for the one-speed and two-speed transmissions make it possible to closely match transmission and engine to any application.

The PR1 and PR2 have relatively few parts, thereby increasing performance life and minimizing service costs. The single piece case with integral sump eliminates oil pan gasket leaks found in other designs. The valve body is located on top of the transmission to provide easy accessibility.

A selection of ratios, mounting configurations and controls allows design flexibility and increased vehicle productivity.

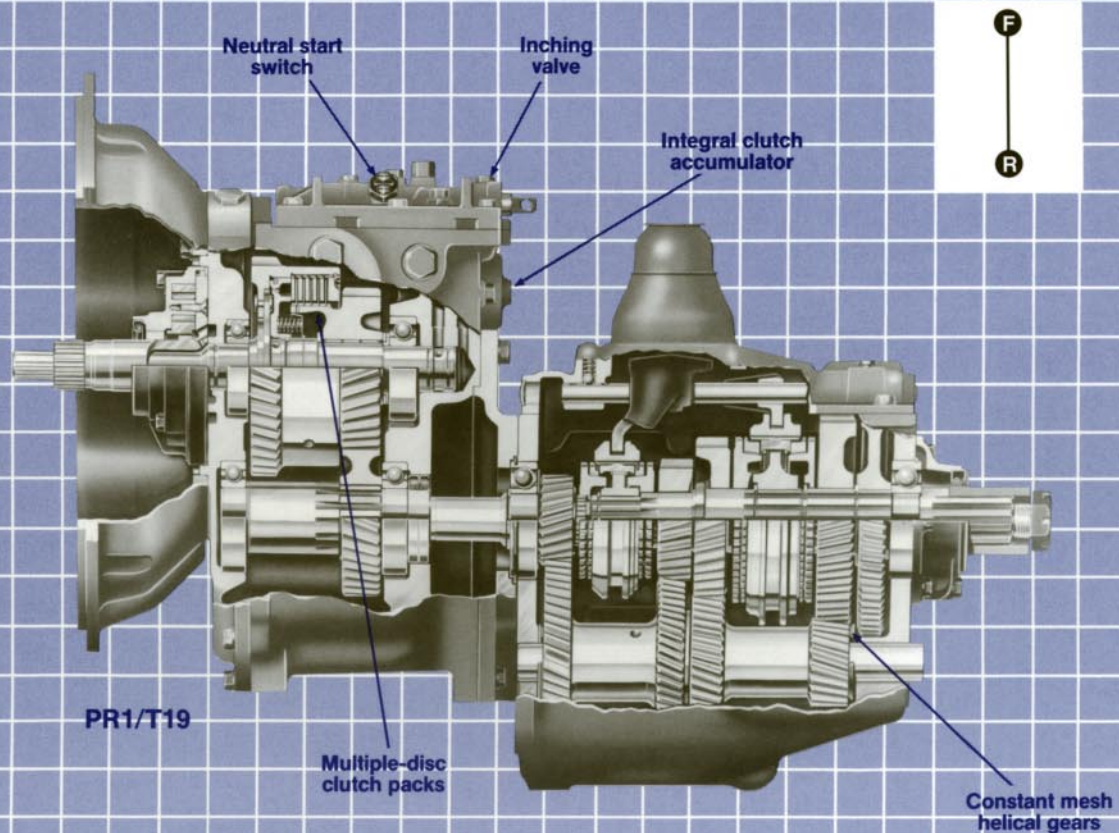

PR Series Features and Benefits

● Identical multiple disc clutch packs for forward and reverse operation	Offers smooth operation through equalized forward and reverse transmission torque capacity, precise inching and long service life.
● Optional auxiliary pump drive	Standardized plumbing harness for use with a variety of engines.
● Constant mesh helical gearing and anti-friction bearings.	Provides quiet, durable operation.
● Neutral start switch	Prevents engine from being started in gear.
● Spin-on filter	Minimizes leakage and makes filter changes easier.
● Pressurized lube system	Increases component service life.
● Optional four-speed range box	Adds ratio flexibility.

All specifications and descriptive data are nominal and subject to change without notice. Specific applications should be referred to Velvet Drive Transmissions for assistance.